

## DIAPHRAGM FAILURE DETECTOR (INTRINSICALLY SAFE COMPONENTS)

(for 1-1/2", 2" and 3" Metallic Diaphragm Pumps with Cast Iron or Stainless Steel center bodies)



**READ THIS MANUAL CAREFULLY BEFORE INSTALLING,  
OPERATING OR SERVICING THIS EQUIPMENT.**

It is the responsibility of the employer to place this information in the hands of the operator. Keep for future reference.

### SENSOR DATA

Protection	The components meet the requirements for Class 1, Division II, Group C environment.
Voltage	30 VDC max.
Sensor Type	Electro-Optic
Sensor Material	Polysulfone

### GENERAL DESCRIPTION

An Aro diaphragm pump equipped with the Aro Diaphragm Failure Detector warns of a diaphragm failure by sensing the presence of liquid in the air chamber of the pump. This system uses a liquid sensor in each of the two air chambers.

### OPERATING INSTRUCTIONS

1. Supply voltage for the components can be through the 95087 cable or through the 95088 adapter (see pinout information on page 2).
2. The cable can be connected to operate an output device as required (valve, buzzer, light, etc.).
3. To clean the sensors, disconnect the 96270-1 sensors from the 95088 adapter. Unthread the sensors from the air caps. Clean the prism of the sensors with a mild detergent or water. **WARNING: Chlorinated hydrocarbons MUST NOT BE USED for cleaning.** See note in 5 below.
4. To reassemble, apply PTFE tape or #80725 Permatex to the threads of each sensor and thread to the air cap. NOTE: Torque the sensors to **NO MORE THAN 120 in. lbs (13.56 Nm)**. Reconnect the sensors to the 95088 adapter.
5. Note: Clean the sensors every 1,000,000 cycles or every 3 months of use.



### INSTALLATION AND WARNINGS

NOTE: The power supply cable is not furnished with the unit and must be supplied by the customer.

ALL WIRING MUST COMPLY WITH ALL LOCAL AND / OR NATIONAL ELECTRICAL CODES.

- Electrical codes that apply must be strictly adhered to; failure to do so may lead to shock hazard or serious injury.
- Some local electrical codes may require the installation of rigid conduit.
- The diaphragm failure detector components must be installed by a qualified electrician in compliance with all national, state and local codes and regulations to reduce the risk of electrical shock or other serious injury during installation and operation.
- ARO is not responsible for accidents resulting from improper installation of components or hardware.

# PINOUT DESCRIPTIONS

## 94712-1 SENSOR PINOUTS

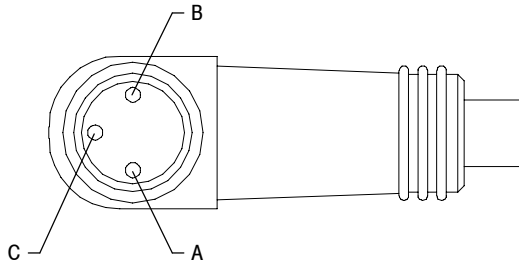

Pinout	Function
A	+24 VDC
B	Ground
C	Signal

## 95087 CABLE PINOUTS

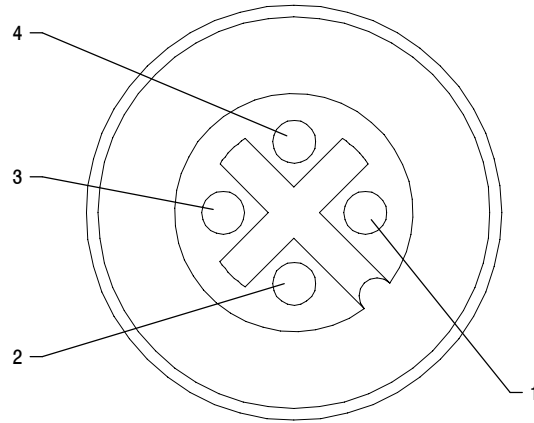

Pinout	Cable Color	Function
1	Brown	+24 VDC
2	White	Signal
3	Blue	Ground
4	Black	Signal

## 95088 ADAPTER PINOUTS

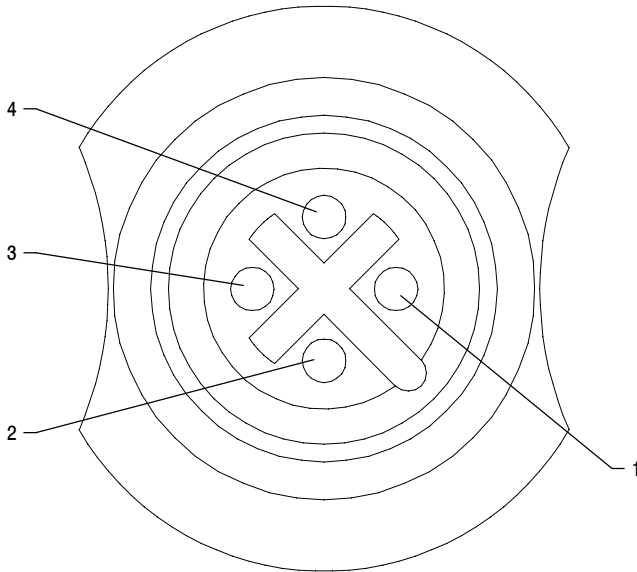

Pinout	Function
1	+24 VDC
2	Signal
3	Ground
4	Signal

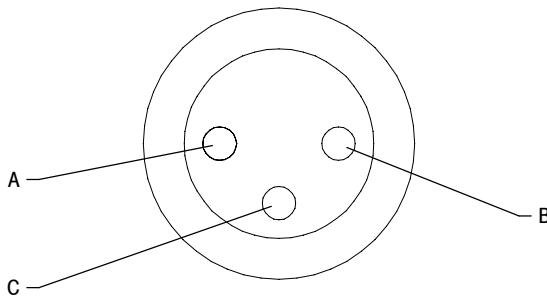

Pinout	Function
A	+24 VDC
B	Ground
C	Signal