

1" Metallic Models

EXP SERIES PUMPS

ARO® EXP 1" metallic diaphragm pumps achieve flow rates of up to 52.2 GPM (197.6 LPM) and offer a wide array of material and porting configurations. These pumps are often used for transfer, filling, recirculation and batching in ceramic, industrial, chemical and petrochemical markets.

UPGRADE
PUMP FOR REMOTE
ACTUATION CAPABILITY

Ratio:	1:1
Maximum GPM (LPM):	52 (197)
Displacement per cycle Gallons (Liters):	0.232 (0.88)
Air Inlet (Female):	1/4 - 18 N.P.T.
Fluid Inlet/Outlet:	1 - 11-1/2 N.P.T.F.-1, Rp1(1-11 BSP)
Max. operating pressure psi (bar):	120 (8.3)
Suspended solids max. dia. in. (mm):	1/8" (3.3)
Weight lbs (kg):	
PX10R-XAX-XXX	20.7 (9.4)
PX10R-XCX-XXX	35.2 (16.0)
PX10R-XHX-XXX	39.6 (18.0)
PX10R-ASX-XXX,	38.2 (17.3)
PX10R-BSX-XXX	
PX10R-FSX-XXX	43.9 (19.9)

Note: Add 4.65 lbs (2.11 kg) for aluminum air motor
Add 11.09 lbs (5.03 kg) for stainless steel air motor

Maximum dry suction lift ft(m):	19 (5.7)
Sound Level:	70 PSI 60 Cycles/Min 80.6 db
Muffler Included:	93110



PD10A-AAP-XXX



PD10A-FSS-XXX

Ordering

Position	1	2		3	4	5		6	7	8		9	10	11
Example:	PX10	X	-	X	X	X	-	X	X	X	-	A	X	X

Position 1 Model Series	Position 2 Center Section	Position 3 Connections	Position 4 Wetted Parts	Position 5 Hardware	Position 6 Seat Material	Position 7 Ball Material	Position 8 Diaphragm Material	Position 9
PD10 - Standard Pump PE10 - Electronic Interface Accessible Pump	A - Aluminum* R - Polypropylene S - Stainless Steel*	A - NPTF Thread B - BSP Thread F - 1" ANSI/DIN Hybrid End Flange with Flat Face	A - Aluminum* C - Cast Iron H - Hastelloy-C* S - Stainless Steel*	P - Plated Steel S - SS	A - Santoprene® C - Hytrel® E - Carbon Steel F - Aluminum G - Nitrile H - 440 SS L - Hastelloy-C S - 316 SS	A - Santoprene® C - Hytrel® G - Nitrile S - 316 SS T - PTFE V - Viton®	A - Santoprene® C - Hytrel® G - Buna-N L - Long-Life PTFE T - PTFE/Santoprene® V - Viton®	Revision Level Position 10 & 11 Specialty Code Fluid control options for pump with electronic interface (PE10 model). See complete description on back page

* Acceptable for use in hazardous locations. - NEC / CEC: Class I&II, Div 1&2, Group A-D
- ATEX: Zone 1&2, 21&22

Hytrel® is a registered trademark of DuPont company, Santoprene® is registered trademark of Monsanto and Viton® is a registered trademark of ExxonMobil

Accessories

Air Line Connection Kit | 66073-2 (Piggyback Filter/Regulator with gauge, pipe nipple and 5-foot air hose)

Diaphragm Failure Detection | 67237

Cycle Sensor Kit | 67350 (PE10X pump model is required)

Service Repair Kits | 637397 (air motor for PX10A, PX10R and PX10S),
637401-XXX (fluid section with seats)
637395-X (major air valve assembly)

1" Metallic Dimensions and Flow Charts

(Dimensions shown are for reference only, they are displayed in inches and millimeters (mm)).

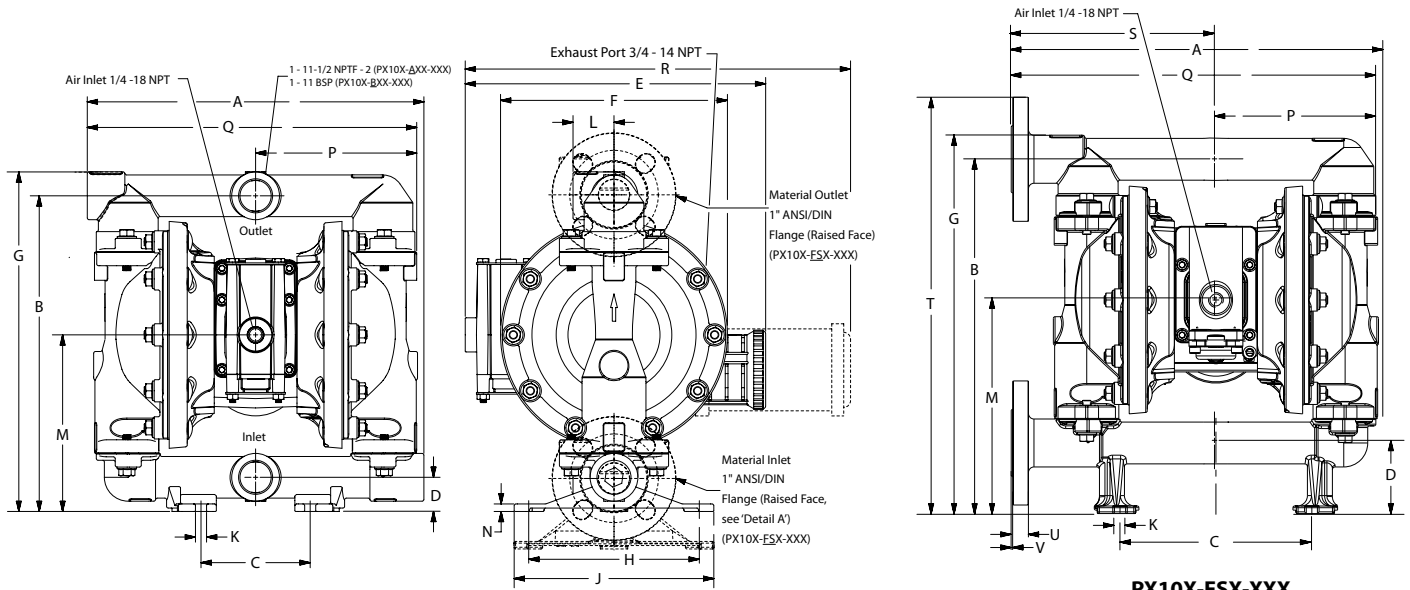

A - 12.34" (313.4 mm)	E - see below	J - 7.31" (185.6 mm)	N - see below	
B - 11.56" (293.6 mm)	F - see below	K - 0.4" (10.1 mm)	P - 5.84" (148.3 mm)	
C - 4" (101.6 mm)	G - 12.43" (315.7 mm)	L - 1.5" (38.1 mm)	Q - 12" (304.8 mm)	
D - 1.25" (31.7 mm)	H - 6.25" (158.7 mm)	M - 6.46" (164.0 mm)	R - see below	
	"E"	"F"	"R"	"N"
PX10A-XXX-XXX	-----	8.12" (206.2 mm)	14.03" (356.3 mm)	PX10X-XAX-XXX 0.25" (6.3 mm)
PX10R-XXX-XXX	11.09" (281.6 mm)	8.31" (211.0 mm)	-----	PX10X-XCX-XXX 0.28" (7.1 mm)
PX10S-XXX-XXX	-----	8.18" (207.7 mm)	13.84" (351.5 mm)	PX10X-XHX-XXX 0.28" (7.1 mm)
				PX10X-XSX-XXX 0.28" (7.1 mm)
PX10X-FSX-XXX				
A - 13.37" (339.5 mm)	D - 2.57" (65.2 mm)	M - 7.79" (197.8 mm)	Q - 13.30" (337.8 mm)	T - 15.19" (385.8 mm)
B - 12.92" (328.1 mm)	G - 13.80" (350.5 mm)	N - 9/32" (7.1 mm)	R - 13.83" (351.2 mm)	U - 0.63" (16.0 mm)
C - 7" (177.8 mm)	K - 0.4" (10.1 mm)	P - 5.83" (148.0 mm)		V - 0.60" (15.2 mm)

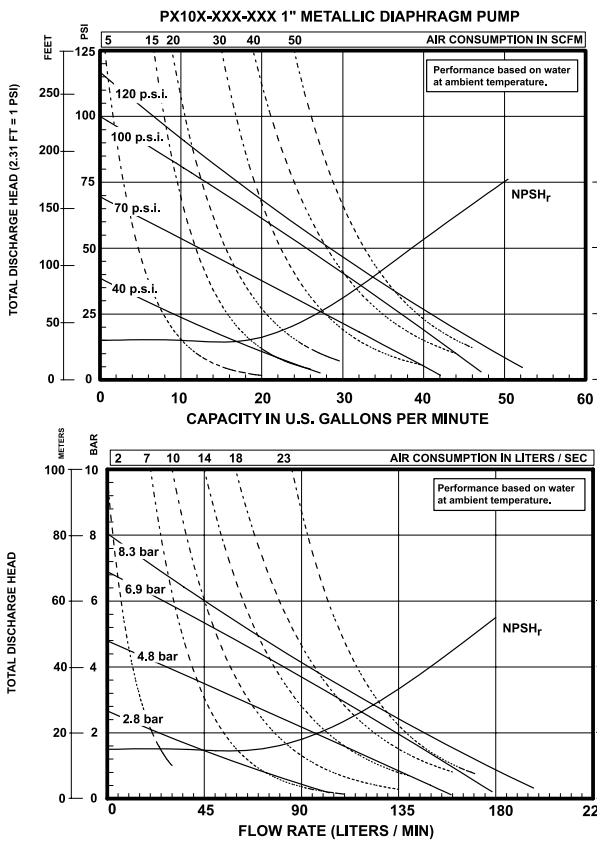

Ordering Position 10 Specialty Code 1 (Blank if no Specialty Code)

A - Solenoid 120VAC	G - Solenoid 12VDC ATEX/IECex*
B - Solenoid 12VDC	H - Solenoid 24VDC ATEX/IECex*
C - Solenoid 240VAC	J - 120VAC NEC/CEC*
D - Solenoid 24VDC	K - Solenoid 220VAC ATEX/IECex*
E - 12VDC NEC/CEC*	N - Solenoid with no coil
F - 24VDC NEC/CEC*	O - Standard Valve Block (No Solenoid)
	P - Ported Motor (No major valve provided)

Ordering Position 11 Specialty Code 2 (Blank if no Specialty Code)

E - End of stroke feedback + Leak Detection	L - Leak Detection
F - End of stroke feedback	M - Leak Detection ATEX/IECex/NEC/CEC*
G - End of Stroke ATEX/IECex*	O - No Option
H - End of Stroke/Leak Detection ATEX/IECex*	R - End of Stroke Feedback NEC / CEC*
	T - End of Stroke Feedback + Leak Detection NEC / CEC*

* Acceptable for use in hazardous locations. - NEC / CEC: Class I&II, Div 1&2, Group A-D
- ATEX: Zone 1&2, 21&22

Performance based on an elastomeric fitted pump, flooded suction with water at ambient conditions. Due to varying materials of construction, assembly configurations and operating conditions, published data is for reference only