

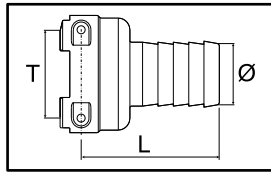

# RACCORDI CON ATTACCO A FORCHETTA FITTINGS WITH FORK COUPLING RACORES CON CONEXION DE HORQUILLA



**Portagomma dritto attacco femmina**  
Straight hose fitting with female connection  
Portamanguera recto con conexión hembra



**Portagomma dritto attacco maschio**  
Straight hose fitting with male connection  
Portamanguera recto con conexión macho

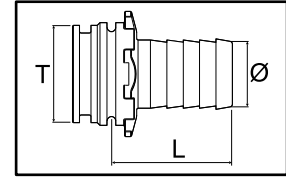

COD. CODE Cód.	T	Ø (mm)	L (mm)		COD. CODE Cód.
109 0113	T1	13	45	25	010001
109 0116		16	45	25	
109 0310	T3	10	48	25	010003
109 0313		13	48	25	
109 0316		16	48	25	
109 0320		20	53	25	
109 0325		25	53	25	
109 0413	T4	13	49	25	010004
109 0416		16	49	25	
109 0420		20	54	25	
109 0425		25	54	25	
109 0430		30	59	25	
109 0513	T5	13	51	10	010005
109 0516		16	51	10	
109 0520		20	56	10	
109 0525		25	56	10	
109 0530		30	61	10	
109 0532		32	61	10	
109 0535		35	63	10	
109 0538		38	69	10	
109 0540	40	69	10		
109 0625	T6	25	60	10	010006
109 0630		30	65	10	
109 0632		32	65	10	
109 0635		35	67	10	
109 0638		38	73	10	
109 0640		40	73	10	
109 0650		50	81	10	
109 0740	T7	40	80	10	010007
109 0745		45	82	10	
109 0750		50	84	10	
109 0752		52	84	10	
109 0760		60	99	10	
109 0960	T9	60	103	5	010009
109 0975		75	113	5	

NYLON®

COD. CODE Cód.	T	Ø (mm)	L (mm)		COD. (EPDM)	COD. (Viton®)
109 1108	T1	8	30	25	G11056	G11056V
109 1110A		10	35	25		
109 1113A		13	35	25		
109 1310	T3	10	37	25	G11058	G11058V
109 1313		13	39	25		
109 1316		16	39	25		
109 1320		20	44	25		
109 1325		25	44	25		
109 1330		30	48	25		
109 1413	T4	13	40	25	G11054	G11054V
109 1416		16	40	25		
109 1420		20	45	25		
109 1425		25	45	25		
109 1430		30	49	25		
109 1513	T5	13	40	10	G11063	G11063V
109 1516		16	40	10		
109 1520		20	45	10		
109 1525		25	45	10		
109 1530		30	50	10		
109 1532		32	50	10		
109 1535		35	52	10		
109 1538		38	58	10		
109 1540	40	58	10			
109 1625	T6	25	48	10	G11023	G11023V
109 1630		30	53	10		
109 1632		32	53	10		
109 1635		35	55	10		
109 1638		38	61	10		
109 1640		40	61	10		
109 1740	T7	40	62	10	G11017 x2	G11017V x2
109 1745		45	64	10		
109 1750		50	69	10		
109 1752		52	69	10		
109 1760		60	84	10		
109 1960	T9	60	86	5	G11067 x2	G11067V x2
109 1975		75	96	5		

NYLON®





# RACCORDI CON ATTACCO A FORCHETTA FITTINGS WITH FORK COUPLING RACORES CON CONEXION DE HORQUILLA



Portagomma curvo 45° attacco femmina  
45° hose fitting with female connection  
Portamanguera curvo 45° conexión hembra

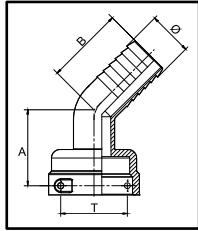

COD. CODE CÓD.	T	Ø (mm)	A (mm)	B (mm)	□	COD. CODE CÓD.
119 2430	T4	30	47	55	25	010004
119 2525	T5	25	50	50	25	010005
119 2530		30	50	55	25	
119 2630	T6	30	54	55	25	010006
119 2635		35	54	55	25	
119 2640		40	54	60	25	
119 2750	T7	50	60	70	10	010007



Portagomma curvo 45° attacco maschio  
45° hose fitting with male connection  
Portamanguera curvo 45° conexión macho

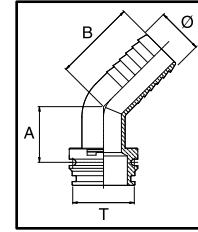

COD. CODE CÓD.	T	Ø (mm)	A (mm)	B (mm)	□	COD. (EPDM)	COD. (Viton®)
119 3525	T5	25	38	50	10	G11063	G11063V
119 3530		30	38	55	10		
119 3535		35	38	55	10		
119 3630	T6	30	41	55	10	G11023	G11023V
119 3635		35	41	55	10		
119 3640		40	41	60	10		
119 3760	T7	60	37	82	10	G11017 x2	G11017V x2

NYLON®



Raccordo filettato maschio attacco femmina  
Male threaded with female connection  
Rosca macho con conexión hembra

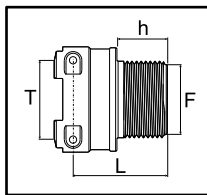

COD. CODE CÓD.	T	F	L (mm)	h (mm)	□	COD. CODE CÓD.
249 033	T3	G 3/4 M	40	22	25	010003
249 044	T4	G 1 M	41	22	25	010004
249 055	T5	G 1 1/4 M	46	24	10	010005
249 064	T6	G 1 M	46	22	10	010006
249 065		G 1 1/4 M	48	24	10	
249 066		G 1 1/2 M	49	24	10	
249 067		G 2 M	47	27	10	
249 074	T7	G 1 M	51	22	10	010007
249 075		G 1 1/4 M	53	24	10	
249 076		G 1 1/2 M	53	24	10	
249 077		G 2 M	59	27	10	



Raccordo filettato maschio attacco maschio  
Male threaded with male connection  
Rosca macho con conexión macho

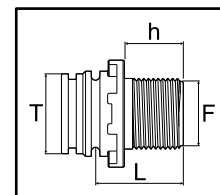

COD. CODE CÓD.	T	F	L (mm)	h (mm)	□	COD. (EPDM)	COD. (Viton®)
249 133	T3	G 3/4 M	33	22	25	G11058	G11058V
249 144	T4	G 1 M	33	22	25	G11054	G11054V
249 155	T5	G 1 1/4 M	37	24	10	G11063	G11063V
249 166	T6	G 1 1/2 M	42	24	10	G11023	G11023V
249 177	T7	G 2 M	45	27	10	G11017x2	G11017Vx2
249 199	T9	G 3 M	54	35	5	G11067x2	G11067Vx2

NYLON®





# RACCORDI CON ATTACCO A FORCHETTA FITTINGS WITH FORK COUPLING RACORES CON CONEXION DE HORQUILLA

**T**  
fork  
coupling

Riduzione maschio / maschio  
Male / male adapter  
Reducción macho / macho

NYLON®

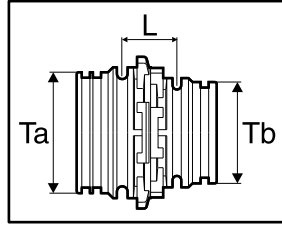

COD. CODE CÓD.	L (mm)	☐	Ta	a			b	
				COD. (EPDM)	COD. (Viton®)	Tb	COD. (EPDM)	COD. (Viton®)
259 134	18	10	T4	G11054	G11054V	T3	G11058	G11058V
259 145	19	10	T5	G11063	G11063V	T4	G11054	G11054V
259 156	23	10	T6	G11023	G11023V	T5	G11063	G11063V
259 167	27	10	T7	G11017 x2	G11017V x2	T6	G11023	G11023V
259 179	30	5	T9	G11067 x2	G11067V x2	T7	G11017 x2	G11017V x2

**T**  
fork  
coupling

Riduzione femmina / maschio  
Female / male adapter  
Reducción hembra / macho

NYLON®

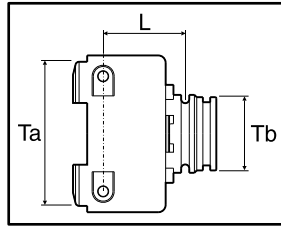

COD. CODE CÓD.	L (mm)	☐	Ta	a		b	
				COD. CODE CÓD.	Tb	COD. (EPDM)	COD. (Viton®)
259 263	34	10	T6	010006	T3	G11058	G11058V
259 267	40	10			T7	G11017 x2	G11017V x2

**T**  
fork  
coupling

Adattatore Camlock attacco femmina  
Camlock adapter with female connection  
Adaptador Camlock con conexión hembra

NYLON®

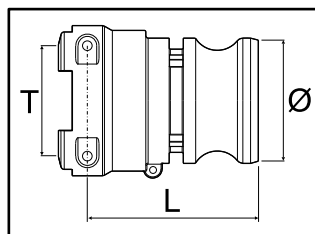

COD. CODE CÓD.	T	Ø	L (mm)	☐	COD. CODE CÓD.
181 06L	T6	1" 1/2	80	5	010006
181 07L	T7	2"	88	5	010007
181 09L	T9	3"	100	5	010009

# RACCORDI CON ATTACCO A FORCHETTA FITTINGS WITH FORK COUPLING RACORES CON CONEXION DE HORQUILLA



**T**  
fork  
coupling

Adattatore maschio flangiato attacco a morsetto\*  
Flanged male adapter, clamp coupling\*  
Adaptador macho con brida toma de mordaza\*

NYLON®

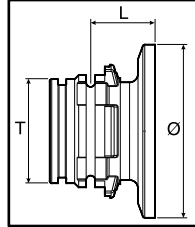

COD. CODE CÓD.	T	Ø	Tipo Type Tipo	L (mm)		COD. (EPDM)	COD. (Viton®)
279 144	T4	1"	---	27	10	G11054	G11054V
279 154	T5	1"	---	28	10	G11063	G11063V
279 157		2"	std. port	28	10		
279 167	T6	2"	std. port	31	10	G11023	G11023V
279 1671		2"	full port	31	10		
279 177	T7	2"	std. port	32	10	G11017 x2	G11017V x2
279 1771		2"	full port	32	10		

\*: Compatibile con attacchi tipo Banjo®, Hypro® e Bee Valve®.  
Suitable for use with Banjo®, Hypro® and Bee Valve® connections.  
Compatible con las conexiones tipo Banjo®, Hypro® y Bee Valve®.

Kit morsetto di serraggio completo di guarnizione e vite.  
Kit of tightening clamp with seal and screw.  
Kit mordaza de ajuste completa con junta y tornillo.



COD. CODE CÓD.	Ø
2790 00.100	1" Full port
2790 00.200	2" Std. port
2790 00.220	2" Full port

**T**  
fork  
coupling

Tappo femmina  
Blanking cap  
Tapón hembra

NYLON®

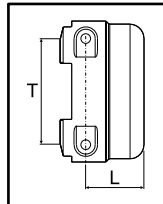

COD. CODE CÓD.	T	L (mm)		COD. CODE CÓD.
219 010	T1	14	25	010001
219 030	T3	18	25	010003
219 040	T4	19	25	010004
219 050	T5	21	10	010005
219 060	T6	24	10	010006
219 070	T7	29	10	010007
219 090	T9	33	10	010009

**T**  
fork  
coupling

Tappo maschio  
Male plug  
Tapón macho

NYLON®

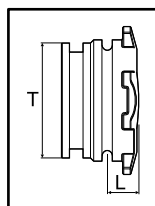

COD. CODE CÓD.	T	L (mm)		COD. (EPDM)	COD. (Viton®)
219 130	T3	9	25	G11058	G11058V
219 140	T4	10	25	G11054	G11054V
219 150	T5	10	10	G11063	G11063V
219 160	T6	13	10	G11023	G11023V
219 170	T7	14	10	G11017 x2	G11017V x2
219 190	T9	16	10	G11067 x2	G11067V x2



# RACCORDI CON ATTACCO A FORCHETTA FITTINGS WITH FORK COUPLING RACORES CON CONEXION DE HORQUILLA

**T**  
fork  
coupling

Raccordo 45° con attacco a forchetta femmina/femmina  
45° fitting with female/female fork connection  
Racor 45° con conexión de horquilla hembra/hembra

**new** **NYLON®**

COD. CODE CÓD.	T	X (mm)	A (mm)	B (mm)	XF (mm)		COD. CODE CÓD.
129 355	T5	31	41	41	48	10	010005
129 366	T6	35	46	46	54	10	010006
129 377	T7	39	53	53	65	10	010007
129 399	T9	44	64	64	95	10	010009

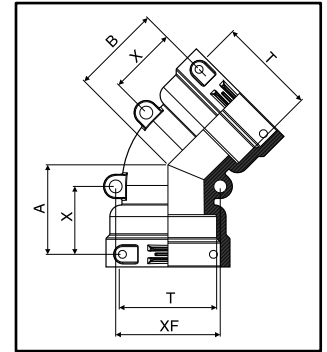

**T**  
fork  
coupling

Raccordo 45° con attacco a forchetta femmina/maschio  
45° fitting with female/male fork connection  
Racor 45° con conexión de horquilla hembra/macho

**NYLON®**

**new**

COD. CODE CÓD.	Ta	Fork		O'ring		X (mm)	X1 (mm)	A (mm)	B (mm)	XF (mm)	
		a	b	COD. (EPDM)	COD. (Viton®)						
129 555	T5	010005	T5	G11063	G11063V	31	20	41	30	48	10
129 566	T6	010006	T6	G11023	G11023V	35	22	46	33	54	10
129 577	T7	010007	T7	G11017 x2	G11017V x2	39	24	53	37	65	10
129 599	T9	010009	T9	G11067 x2	G11067V x2	44	25	64	45	95	10

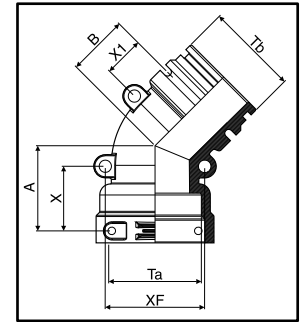

**T**  
fork  
coupling

Raccordo 45° filettato maschio con attacco a forchetta femmina  
45° fitting male threaded with female fork connection  
Racor 45° con rosca macho y conexión de horquilla hembra

**NYLON®**

COD. CODE CÓD.	T	M (BSP)	h (mm)	X (mm)	X1 (mm)	A (mm)	B (mm)	XF (mm)		COD. CODE CÓD.
119 27B7	T7	G2	27	39	16.5	52.5	57	65	10	010007

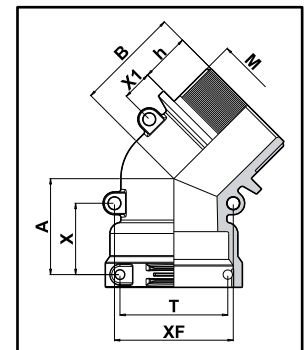



# RACCORDI CON ATTACCO A FORCHETTA FITTINGS WITH FORK COUPLING RACORES CON CONEXION DE HORQUILLA



**T**  
fork  
coupling

Curva 90° femmina / femmina  
90° female / female elbow  
Curva 90° hembra / hembra

**NYLON®**

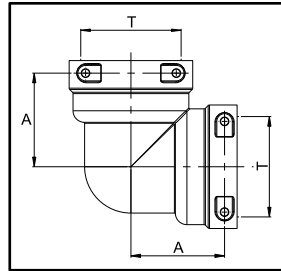

COD. CODE Cód.	T	A (mm)		COD. CODE Cód.
129 033	T3	32	10	010003
129 044	T4	36	10	010004
129 055	T5	41	10	010005
129 066	T6	49	10	010006
129 077	T7	57	5	010007
129 099	T9	75	5	010009

**T**  
fork  
coupling

Curva 90° femmina / maschio  
90° female / male elbow  
Curva 90° hembra / macho

**NYLON®**

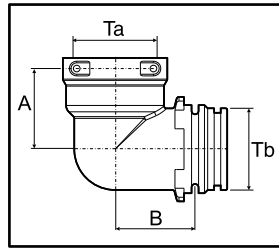

COD. CODE Cód.	A (mm)	B (mm)		Ta	COD. CODE Cód.	Tb	COD. (EPDM)	COD. (Viton®)
129 266	54	49	5	T6	010006	T6	G11023	G11023V
129 277	57	52	5	T7	010007	T7	G11017 x2	G11017V x2

**T**  
fork  
coupling

Collettore a 3 vie  
3-way manifold  
Colector de tres vías

**NYLON®**

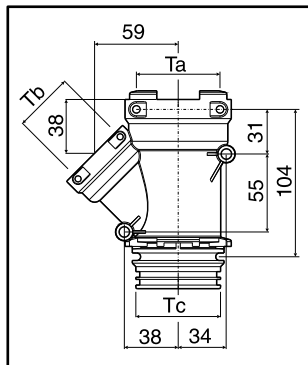

COD. CODE Cód.		Ta	COD. CODE Cód.	Tb	COD. CODE Cód.	Tc	COD. (EPDM)	COD. (Viton®)
179 275	5	T7	010007	T5	010005	T7	G11017x2	G11017V x2

**T**  
fork  
coupling

Raccordo 4 vie a 90° con attacco femmina  
90° 4-way fitting with female connector  
Empalme de 4 vías a 90° con toma hembra

**NYLON®**

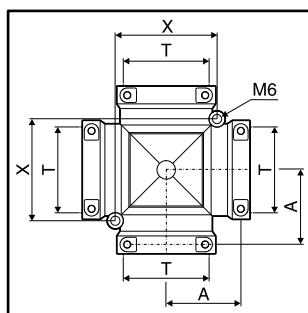

COD. CODE Cód.	T	A (mm)	X (mm)		COD. CODE Cód.
159 033	T3	32	44	10	010003
159 055	T5	41	59	10	010005
159 066	T6	49	67	10	010006
159 077	T7	57	77	5	010007
159 099	T9	75	108	5	010009



# RACCORDI CON ATTACCO A FORCHETTA FITTINGS WITH FORK COUPLING RACORES CON CONEXION DE HORQUILLA

I raccordi ARAG a "T" con attacco a forchetta possono essere fissati ad una superficie, mediante due viti a testa esagonale da inserire nelle asole poste sulla parte superiore del raccordo.

ARAG T-shaped fittings with fork coupling can be fixed to a surface by means of two hexagonal-head screws to be fitted in the slots located on fitting upper side.

Los empalmes ARAG en "T" con toma de horquilla, pueden ser fijados a una superficie, a través de dos tornillos de cabeza exagonal para introducir en los ojales ubicados en la parte superior del empalme.

**T**  
fork  
coupling  
Raccordo a "T" con attacco femmina  
Tee fitting with female connection  
Racor en "T" con conexión hembra



COD. CODE CÓD.	T	A (mm)	B (mm)	C (mm)	D (mm)	M		COD. CODE CÓD.
139 033	T3	63	32	14	25	M5	10	010003
139 044	T4	71	36	14	27	M5	10	010004
139 055	T5	81	41	16	32	M6	10	010005
139 066	T6	97	49	24	35	M6	10	010006
139 077	T7	113	57	32	41	M6	5	010007
139 099	T9	150	75	50	57	M8	5	010009

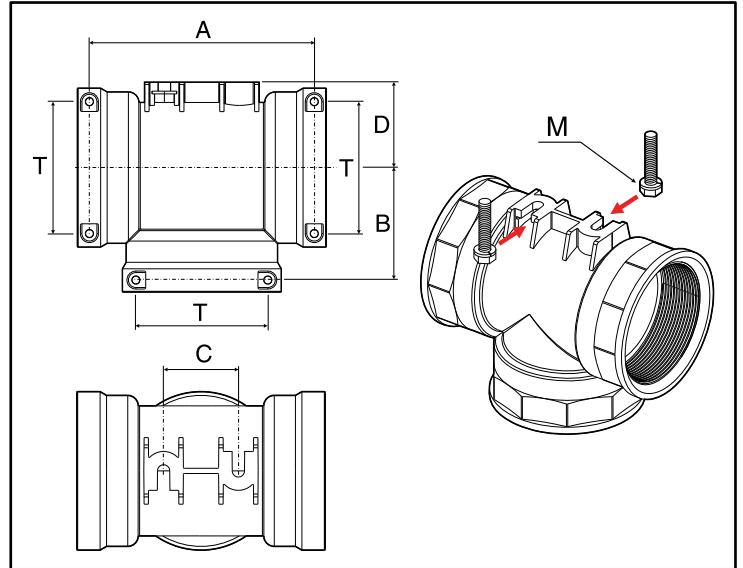

NYLON®

**T**  
fork  
coupling  
Raccordo a "T" con attacco maschio  
Tee fitting with male connection  
Racor en "T" con conexión macho

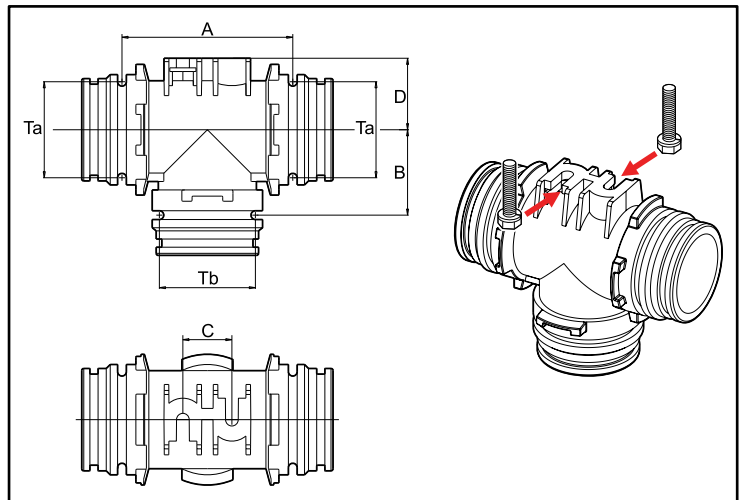

COD. CODE CÓD.	A (mm)	B (mm)	C (mm)	D (mm)		Ta	a		Tb	b	
							COD. (EPDM)	COD. (Viton®)		COD. (EPDM)	COD. (Viton®)
139 165	84	38	24	35	5	T6	G11023	G11023V	T5	G11063	G11063V
139 166	84	42	24	35	5	T6	G11023	G11023V	T6	G11023	G11023V

NYLON®

Raccordo portagomma dritto filetto maschio  
Straight hose fitting with male thread  
Racor portamangueras recto rosca macho



Raccordo portagomma curvo 45° filetto maschio  
45° hose fitting with male thread  
Racor portamangueras curvo 45° rosca macho



Raccordo portagomma curvo filetto maschio  
90° hose fitting with male thread  
Racor portamangueras curvo rosca macho

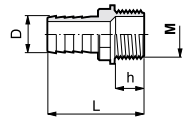

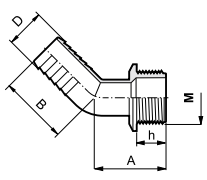

COD. CODE CÓD.	M (BSP)	D (mm)	h (mm)	L (mm)	
103 2008	G 1/4	8	13	47	25
103 2010		10	13	52	25
103 2013		13	13	52	25
103 2108	G 3/8	8	16	52	25
103 2110		10	16	57	25
103 2113		13	16	57	25
103 2115	G 1/2	16	16	57	25
103 2210		10	18	60	25
103 2213		13	18	60	25
103 2215	G 1/2	16	18	60	25
103 2220		20	18	65	25
103 2313		G 3/4	13	22	66
103 2315	16		22	66	25
103 2320	20		22	71	25
103 2322	G 3/4	22	22	71	25
103 2325		25	22	71	25
103 2420		G 1	20	22	72.5
103 2422	22		22	72.5	25
103 2425	25		22	72.5	25
103 2430	G 1	30	22	77.5	25
103 2432		32	22	77.5	25
103 2520		G 1 1/4	20	24	75
103 2525	25		24	75	25
103 2530	30		24	80	25
103 2532	G 1 1/4	32	24	80	25
103 2535		35	24	85	25
103 2538		38	24	85	25
103 2540	G 1 1/2	40	24	90	25
103 2630		30	24	80	10
103 2632		32	24	80	10
103 2635	G 1 1/2	35	24	85	10
103 2638		38	24	85	10
103 2640		40	24	90	10
103 2645	G 2	45	24	90	10
103 2650		50	24	95	10
103 2750		50	27	101	10
103 2760	G 2 1/2	60	27	112.5	10
103 2860		60	32	120	5
103 2975		G 3	75	35	138.5

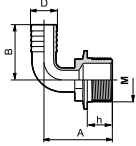

COD. CODE CÓD.	M (BSP)	D (mm)	h (mm)	A (mm)	B (mm)	
114 530	G 1 1/4	30	23.5	57.5	55	10
114 535		35	23.5	57.5	55	10
114 540	G 1 1/2	40	23.5	57.5	60	10
114 630		30	24	58.5	55	10
114 635	G 1 1/2	35	24	58.5	55	10
114 640		40	24	58.5	60	10



COD. CODE CÓD.	M (BSP)	D (mm)	h (mm)	A (mm)	B (mm)	
113 2113	G 3/8	13	16	41	45	25
113 2115		16	16	41	48	25
113 2213	G 1/2	13	18	44	45	25
113 2215		16	18	44	48	25
113 2220		20	18	44	53	25
113 2313	G 3/4	13	22	50	45	25
113 2315		16	22	50	48	25
113 2320		20	22	50	53	25
113 2325	G 1	25	18	55	53	25
113 2420		20	22	50	53	25
113 2425		25	22	59	53	25
113 2430	G 1	30	22	60	60	25
113 2432		32	22	60	60	25
113 2525		G 1 1/4	25	24	65.5	53
113 2530	30		24	62	60	25
113 2532	32		24	62	60	25
113 2535	G 1 1/4	35	24	70	80	10
113 2538		38	24	70	84.5	10
113 2540		40	24	70	84.5	10
113 2630	G 1 1/2	30	24	62	60	10
113 2632		32	24	62	60	10
113 2635		35	24	70	80	10
113 2638	G 1 1/2	38	24	70	84.5	10
113 2640		40	24	70	84.5	10
113 2750		G 2	50	27	88	89
113 2752	52		27	88	89	10
113 2960	G 3	60	35	125	120	5
113 2975		75	35	125	125	5
Passaparete	Bulkhead		Pasapared			
113 213L	G 1/2	13	27	50	45	25
113 215L		16	27	50	48	25
113 220L		20	27	50	53	25

Raccordo portagomma dritto filetto femmina  
Straight hose fitting with female thread  
Racor portamangueras recto rosca hembra



COD. CODE CÓD.	F (BSP)	D (mm)	h (mm)	L (mm)	
100 215	G 1/2	16	15.5	49	25
100 219		19	15.5	54.5	25
100 519	G 1 1/4	19	28.5	69	25
100 521		21	28.5	69	25
100 525		25	28.5	69	25
100 530		30	28.5	77.5	25
100 533		32	28.5	77.5	25
100 535		35	28.5	77.5	25
100 540		40	28.5	77.5	25
100 635	G 1 1/2	35	19	67	10
100 640		40	19	67	10
100 645		45	19	63	10
100 650	G 2	50	19	61	10
100 745		45	21	70	10
100 750		50	21	70	10
100 760		60	21	75	10

**NYLON® PA66**

Raccordo portagomma curvo filetto femmina  
90° hose fitting with female thread  
Racor portamangueras curvo rosca hembra



COD. CODE CÓD.	F (BSP)	D (mm)	h (mm)	A (mm)	B (mm)	
110 2320	G 3/4	20	23	51	47	25
110 322		22	23	58	53	25
110 2325		25	23	51	50	25
110 330		30	26	53	57	25
110 2430	G 1	30	23	51	55	25
110 2432		32	23	51	55	25

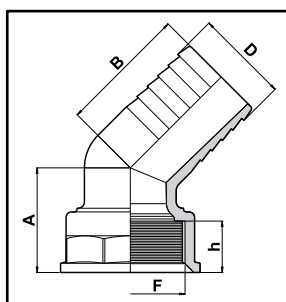

Raccordo portagomma 45° filetto femmina  
45° hose fitting with female thread  
Racor portamangueras 45° con rosca hembra



COD. CODE CÓD.	F (BSP)	D (mm)	h (mm)	A (mm)	B (mm)	
111 750	G2	50	28	57	70	10



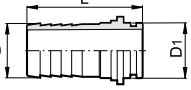

Raccordo portagomma dritto per girello  
Straight hose fitting for fly nut  
Racor portamanguera recto para tuerca



X		Y					Z
							
COD. CODE Cód.	F (BSP)	D (mm)	COD. CODE Cód.	D1 (mm)	L (mm)		COD. CODE Cód.
200 2020	G 1/2	10	106 210	13.7	42.5	25	G 11060
		13	106 213	13.7	42.5	25	
200 2030	G 3/4	13	106 313	17.5	44	25	G 10031
		16	106 315	17.5	44	25	
		20	106 320	17.5	49	25	
200 2040	G 1	13	106 413	24.5	46.5	25	G 10041
		16	106 415	24.5	46.5	25	
		20	106 420	24.5	51.5	25	
		22	106 422	24.5	51.5	25	
200 2050	G 1 1/4	25	106 425	24.5	51.5	25	G 10051
		22	106 522	31.5	53	25	
		25	106 525	31.5	53	25	
		30	106 530	31.5	66	25	
200 2060	G 1 1/2	32	106 533	31.5	63.5	25	G 10061
		25	106 625	37.5	53	25	
		30	106 630	37.5	59	25	
		32	106 633	37.5	59	25	
200 2070	G 2	35	106 635	37.5	64	25	G 10061
		38	106 638	37.5	64	25	
		40	106 640	37.5	68	25	
		40	106 740	47	76	10	
200 2080	G 2 1/2	45	106 745	47	76	10	G 10071 (X2)
		50	106 750	47	81	10	
		52	106 752	47	81	10	
		60	106 860	63	94.5	5	
200 2090	G 3	60	106 960	75	101	5	G 10081 (X2)
		75	106 975	75	115	5	

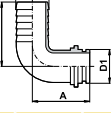

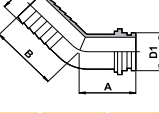

Raccordo portagomma curvo per girello  
90° hose fitting for fly nut  
Racor portamanguera curvo para tuerca

X		Y					Z	
								
COD. CODE Cód.	F (BSP)	D (mm)	COD. CODE Cód.	D1 (mm)	A (mm)	B (mm)		COD. CODE Cód.
200 2020	G 1/2	10	116 210	13.7	35	33	25	G 11060
200 2030	G 3/4	13	116 313	17.5	35.5	39.5	25	G 10031
		16	116 315	17.5	37	45	25	
		17	116 317	17.5	39.5	39	25	
		20	116 320	17.5	38.5	45	25	
200 2040	G 1	15	116 415	24.5	37	45	25	G 10041
		20	116 420	24.5	37	45	25	
		25	116 425	24.5	47	53	25	
200 2050	G 1 1/4	22	116 522	31.5	51	53	25	G 10051
		25	116 525	31.5	51	53	25	
		30	116 530	31.5	53.5	60	25	
200 2060	G 1 1/2	32	116 533	31.5	53.5	60	25	G 10061
		25	116 625	37.5	59.5	53	25	
		30	116 630	37.5	53.5	60	25	
		32	116 633	37.5	53.5	60	25	
200 2070	G 2	35	116 635	37.5	64.5	84.5	25	G 10061
		38	116 638	37.5	64.5	84.5	25	
		40	116 640	37.5	64.5	84.5	25	
		40	116 740	47	64	84.5	10	
200 2080	G 2 1/2	45	116 745	47	71.5	90	10	G 10071 (X2)
		50	116 750	47	75	89	10	
		52	116 752	47	75	89	10	
200 2090	G 3	60	116 860	63	95	120	5	G 10081 (X2)
200 2090	G 3	60	116 960	75	108	120	5	G 10091 (X2)
		75	116 975	75	108	125	5	

Raccordo portagomma curvo a 45° per girello  
45° hose fitting for fly nut  
Racor portamanguera curvo a 45° para tuerca

X		Y					Z	
								
COD. CODE Cód.	F (BSP)	D (mm)	COD. CODE Cód.	D1 (mm)	A (mm)	B (mm)		COD. CODE Cód.
200 2020	G 1/2	13	117 213	13.7	27	24	25	G 11060
200 2050	G 1 1/4	30	117 530	31.5	45	55	10	G 10051
		32	117 532	31.5	45	55	10	
200 2060	G 1 1/2	30	117 630	37.5	46.5	55	10	G 10061
		32	117 632	37.5	46.5	55	10	
		35	117 635	37.5	46.5	55	10	
		40	117 640	37.5	46.5	60	10	
200 2070	G 2	45	117 745	47	47	65	10	G 10071 (X2)
		50	117 750	47	47	68	10	

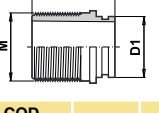
Giunto filettato maschio per girello  
Coupling with male thread for fly nut  
Unión roscada macho para tuerca

X		Y					Z
							
COD. CODE Cód.	F (BSP)	M (BSP)	COD. CODE Cód.	D1 (mm)	L (mm)		COD. CODE Cód.
200 2030	G 3/4	G 3/8	265 031	*	22	25	*
200 2050	G 1 1/4	G 1	265 054	31.5	42	25	G 10051
200 2060	G 1 1/2	G 1 1/4	265 065	37.5	51	25	G 10061
200 2070	G 2	G 1 1/2	265 076	47	61	25	G 10071 (X2)

\* con sede piana. Guarnizione G40013

\* with flat seat. Gasket G40013

\* con sede plana. Junta G40013

**NYLON® PA66**



Raccordo portagomma dritto con sede piana per girello  
Flat seat straight hose tail for fly nut  
Racor portamanguera recto con asiento plano para tuerca

COD. CODE Cód.	F (BSP)	D (mm)	COD. CODE Cód.	D1 (mm)	L (mm)	COD. CODE Cód.	
							O'ring
200 010	G 3/8	8 10	105 108 105 110	15	31 35.5	25	424 190
200 2020	G 1/2	10 13	105 210 105 213	18	36	25	G 40012
200 2030	G 3/4	13 16 20	105 313 105 315 105 320	24	36	25	G 40013
200 2040	G 1	20 25	105 420 105 425	30	41.5	25	G 40014
200 2050	G 1 1/4	30	105 530	38.5	51.5	25	G 40015
200 2060	G 1 1/2	40	105 640	44.5	56	10	G 40004



Raccordo portagomma curvo con sede piana per girello  
90° hose tail flat seat for fly nut  
Racor portamanguera curvo con asiento plano para tuerca

COD. CODE Cód.	F (BSP)	D (mm)	COD. CODE Cód.	D1 (mm)	A (mm)	B (mm)	COD. CODE Cód.	
								O'ring
200 2020	G 1/2	10	115 210	18	28.5	33	25	G 40012
200 2030	G 3/4	13	115 313	24	31.5	35.5	25	G 40013
		16	115 315	24	29	45	25	
		20	115 320	24	30.5	45	25	
200 2040	G 1	25	115 425	30	35.5	53	25	G 40014
200 2050	G 1 1/4	30	115 530	38.5	44	60	25	G 40015
200 2060	G 1 1/2	40	115 640	44.5	52.5	84.5	10	G 40004

NYLON® PA66

COME ORDINARE HOW TO ORDER COMO PEDIR

Specificare i codici X + Y + Z Es. girello 200 2030 + raccordo 105 315 + guarnizione G 40013  
Specify codes # X + Y + Z Ex. fly nut 200 2030 + fitting 105 315 + gasket G 40013  
Specificar los códigos X + Y + Z Ex. tuerca 200 2030 + racor 105 315 + junta G 40013



Raccordo passaparete tutto un pezzo dritto con ghiera  
One-piece bulkhead hose tail with lock ring  
Racor pasapared de una sola pieza recto con tuerca

COD. CODE Cód.	M (BSP)	h (mm)	L (mm)	D (mm)	D1 (mm)	P (mm)
108 425	G 1	15	58	25	45	30



Raccordo passaparete tutto un pezzo curvo con ghiera  
90° one-piece bulkhead hose tail with lock ring  
Racor pasapared de una sola pieza curvo con tuerca

COD. CODE Cód.	M (BSP)	h (mm)	D (mm)	D1 (mm)	A (mm)	B (mm)
118 213	G 1/2	22	11÷13	32	45	77
118 215	G 1/2	22	15÷17	32	49	84
118 319	G 3/4	23	20÷22	40	69	107
118 426	G 1	23	26÷29	50	69	107

Guarnizioni, pagina 277. Gaskets, page 277. Juntas, page 277.





Nuova serie di raccordi maschio e femmina filettatura **GAS**, con maggiore resistenza alla pressione e nuovo sistema di tenuta con OR.

New series of male and female **BSP** thread fittings, with enhanced strength under pressure and a new OR sealing system.

Nueva serie de racores macho y hembra roscado **GAS**, con mayor resistencia a la presión y nuevo sistema de estanqueidad con OR.

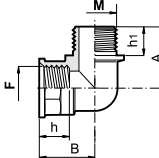
**Raccordo curvo 90° maschio/femmina  
Male/female 90° fitting  
Racor curvo macho/hembra**



COD. CODE Cód.	F/M* (BSP)	h (mm)	h1 (mm)	A (mm)	B (mm)		COD. CODE Cód.
126 2022	G 1/2	21	18	35	33.5	25	G 10041
126 2033	G 3/4	23	22	40.5	38.5	25	G 11058
126 2044	G 1	23	22	47	42.5	25	G 11059
126 2055	G 1 1/4	25	24	53	50	10	G 10052
126 2066	G 1 1/2	25	24	57	52.5	10	G 10062
126 2077	G 2	28	27	66	62.5	10	G 10073

\* A richiesta filettature NPT

\* NPT threads on request

\* A pedido roscas NPT





O'ring

Schema di montaggio raccordi con tenuta tramite OR  
Assembly diagram for fittings with OR seal  
Esquema de montaje racores con estanqueidad mediante OR



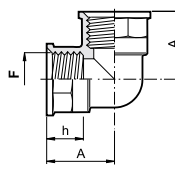

**Raccordo curvo 90° femmina/femmina  
Female/female 90° fitting  
Racor curvo 90° hembra/hembra**

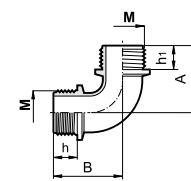

COD. CODE Cód.	F* (BSP)	h (mm)	A (mm)		COD. CODE Cód.
120 2022	G 1/2	21	33.5	25	G 10041
120 2033	G 3/4	23	38.5	25	G 11058
120 2044	G 1	23	42.5	25	G 11059
120 2055	G 1 1/4	25	50	10	G 10052
120 2066	G 1 1/2	25	52.5	10	G 10062
120 2077	G 2	28	62.5	10	G 10073
120 2099	G 3	36	84.5	5	G 10092

**Raccordo curvo 90° maschio/maschio  
Male/male 90° fitting  
Racor curvo 90° macho/macho**

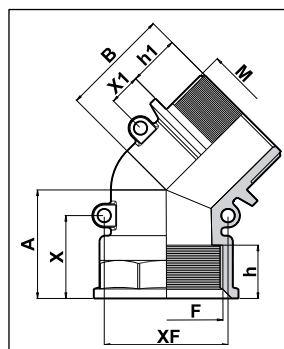

COD. CODE Cód.	M (BSP)	h (mm)	h1 (mm)	A (mm)	B (mm)	
123 044	G 1	19.5	19.5	54	54	25
123 055	G 1 1/4	20.5	20.5	66.5	64.5	10
123 255	G 1 1/4	23	40.5	79.5	55	10
123 2077	G 2	27	27	89	89	10

**Raccordo 45° filettato femmina/maschio  
Female/Male 45° threaded fitting  
Racor 45° con rosca hembra/macho**





COD. CODE Cód.	F (BSP)	M (BSP)	h (mm)	h1 (mm)	XF (mm)	X (mm)	X1 (mm)	A (mm)	B (mm)		COD. CODE Cód.
127 077	G 2	G 2	28	27	65	43.5	16.5	57	57	10	G10073



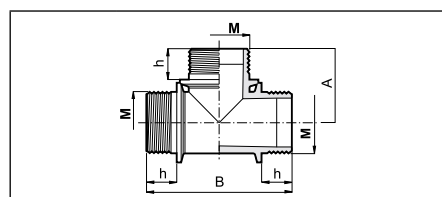

Raccordo a "T" maschio  
Male Tee  
Racor en "T" macho

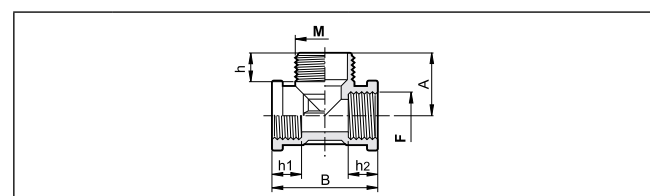

COD. CODE CÓD.	M (BSP)	h (mm)	A (mm)	B (mm)	
131 2050	G 1 1/4	24	54	108	10
131 2060	G 1 1/2	24	57.5	115	10
131 2070	G 2	27	67.5	135	10

Raccordo a "T" maschio/femmina  
Male/female Tees  
Racor en "T" macho/hembra



COD. CODE CÓD.	M (BSP)	F (BSP)	h (mm)	h1 (mm)	h2 (mm)	A (mm)	B (mm)	
133 024	G 1	G 1/2	16	17.5	17.5	35	60	25
133 034	G 1	G 3/4	16	16.5	16.5	35	60	25

Raccordo a "T" femmina  
Female Tee  
Racor en "T" hembra

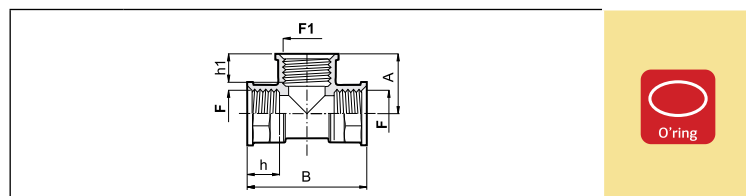

COD. CODE CÓD.	F (BSP)	F1 (BSP)	h (mm)	h1 (mm)	A (mm)	B (mm)		COD. CODE CÓD.
130 2020	G 1/2	G 1/2	21	21	33.5	67	25	G 10041
130 2032	G 1/2	G 3/4	21	23	38.5	67	25	G 10041 + G 11058
130 2030	G 3/4	G 3/4	23	23	38.5	77	25	G 11058
130 2023	G 3/4	G 1/2	23	21	38.5	77	25	G 10041 + G 11058
130 2040	G 1	G 1	23	23	42.5	85	10	G 11059
130 2050	G 1 1/4	G 1 1/4	25	25	50	100	10	G 10052
130 2060	G 1 1/2	G 1 1/2	25	25	52.5	105	10	G 10062
130 2070	G 2	G 2	28	28	62.5	125	10	G 10073

Raccordo a "T" femmina/maschio  
Female/male Tees  
Racor en "T" hembra/macho

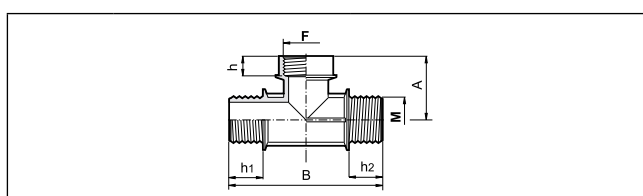

COD. CODE CÓD.	M (BSP)	F (BSP)	h (mm)	h1 (mm)	h2 (mm)	A (mm)	B (mm)	
132 2040	G 1	G 1	23	22	22	42	98	25
132 050	G 1 1/4	G 1 1/4	18	16	31	58.5	126	10
132 2070	G 2	G 2	28	27	27	67.5	135	10

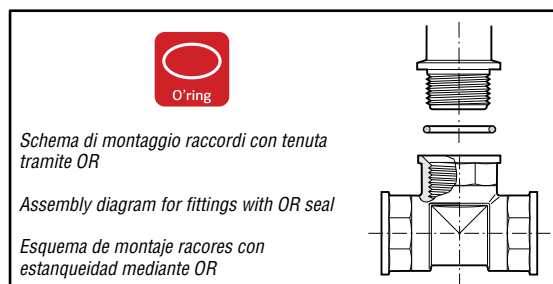



Raccordi a "T" con asole di fissaggio

Union "Tees" with fastening slots

Empalmes en "T" con ojales de fijación



Raccordo a "T" femmina  
Female Tee  
Racor en "T" hembra

COD. CODE CÓD.	F (BSP)	F1 (BSP)	h (mm)	h1 (mm)	A (mm)	B (mm)	C (mm)		COD. CODE CÓD.
130 2090	G 3	G 3	36	36	84.5	169	25	5	G 10092



Raccordo a "T" femmina/maschio  
Female/male Tees  
Racor en "T" hembra/macho

COD. CODE CÓD.	M (BSP)	F (BSP)	h (mm)	h1 (mm)	h2 (mm)	A (mm)	B (mm)	C (mm)		COD. CODE CÓD.
132 2090	G 3	G 3	36	35	35	84.5	180	25	5	G 10092

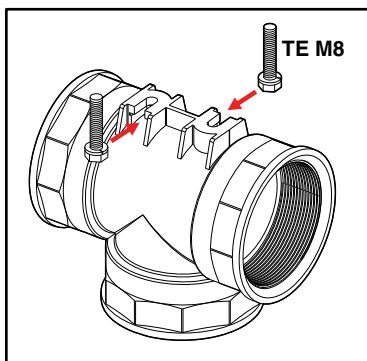

Il raccordo può essere fissato ad una superficie, mediante due viti M8 a testa esagonale da inserire nelle asole poste sulla parte superiore del raccordo.

The union is fastened to a surface with two M8 hexagonal-head screws inserted into slots on the upper part of the union.

El empalme puede ser fijado a una superficie por medio de dos tornillos M8 de cabeza hexagonal para introducir en los ojales colocados en la parte superior del empalme.



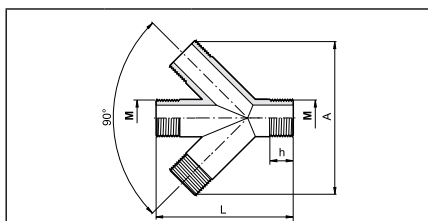

Raccordo a quattro vie a 45° maschio  
45°, four-way male fitting  
Racor de cuatro vías a 45° macho

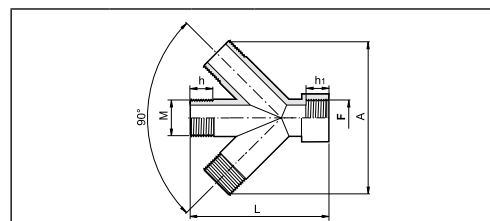

COD. CODE CÓD.	M (BSP)	h (mm)	L (mm)	A (mm)	
160 020	G 1/2	15	80	89	25

Raccordo a quattro vie a 45° maschio/femmina  
45°, four-way male/female fitting  
Racor de cuatro vías a 45° macho/hembra



COD. CODE CÓD.	M (BSP)	h (mm)	h1 (mm)	L (mm)	A (mm)	
160 120	G 1/2	15	13	81	89	25

Raccordo a "Y"  
"Y" fitting  
Racor en "Y"

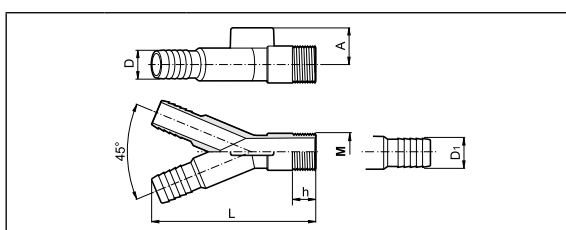

COD. CODE CÓD.	D (mm)	M (BSP)	h (mm)	D1 (mm)	L (mm)	A (mm)	
140 001	25	G 1	21	---	148	33	10
140 002	25	---	---	25	148	33	10
140 003	25	---	---	30	148	33	10



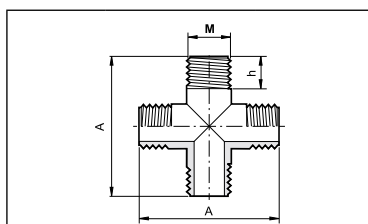

Raccordo a quattro vie a 90° maschio  
90°, four-way male fitting  
Racor de cuatro vías a 90° macho

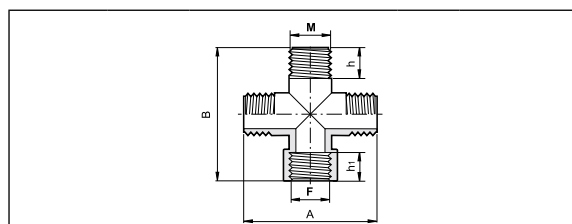

COD. CODE CÓD.	M (BSP)	h (mm)	A (mm)	
150 020	G 1/2	16	69	25

Raccordo a quattro vie a 90° maschio/femmina  
90°, four-way male/female fitting  
Racor de cuatro vías a 90° macho/hembra





COD. CODE CÓD.	M (BSP)	F (BSP)	h (mm)	h1 (mm)	A (mm)	B (mm)	
150 120	G 1/2	G 1/2	16	15.5	69	69.5	25

Collettore filettato 3-6 vie  
3-6 way threaded manifold  
Colector roscado de 3-6 vías

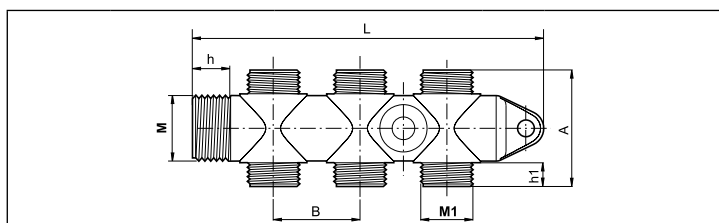

NYLON® PA66



COD. CODE CÓD.	vie ways vias	M (BSP)	M1 (BSP)	h (mm)	h1 (mm)	A (mm)	B (mm)	L (mm)	
152 343	3	G 1	G 3/4	19	11.5	46.5	44	178	10
152 643	6	G 1	G 3/4	19	11.5	58	44	178	10



Girello  
Fly nut  
Tuerca

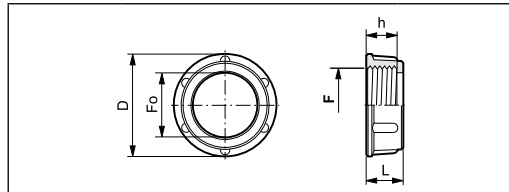

COD. CODE CÓD.	F (BSP)	h (mm)	L (mm)	D (mm)	F0 (mm)	
200 010	G 3/8	14	18	29	13	25
200 2020	G 1/2	13	16.5	31	15.5	25
200 2024	G 1/2	15	19	28.5	12.5	25
200 2030	G 3/4	13.5	17	38	21.8	25
200 2040	G 1	17.5	21	46	27.8	25
200 2050	G 1 1/4	18	22	57	35	25
200 2060	G 1 1/2	19	23.5	64	41	25
200 2070	G 2	19	23.5	77	53.5	10
200 2080	G 2 1/2	20	24.5	92	66	10
200 2090	G 3	25.5	30	105	77	10



Ghiera  
Lock ring  
Tuerca

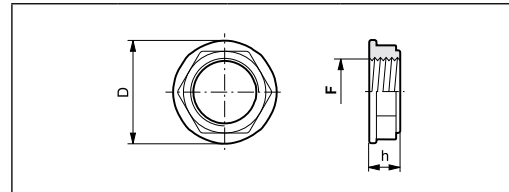

COD. CODE CÓD.	F (BSP)	h (mm)	D (mm)	
205 010	G 3/8	13	30.5	25
205 2020	G 1/2	13	34	25
205 2030	G 3/4	13	44	25
205 2040	G 1	15.5	50	25
205 2050	G 1 1/4	14.3	59	25
205 2060	G 1 1/2	15	67	25
205 2070	G 2	19.5	80	10
205 2080	G 2 1/2	20	100	10
205 2090	G 3	22	110	10
205 0E0	M24 x 2	9.5	40	25



Tappo femmina  
Blanking cap  
Tapón hembra

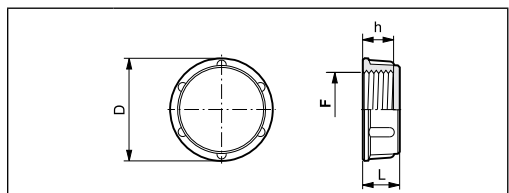

COD. CODE CÓD.	F (BSP)	h (mm)	L (mm)	D (mm)	
210 005	G 1/4	7.5	10.5	19	25
210 010	G 3/8	14	18	29	25
210 2020	G 1/2	13	17.5	31	25
210 2030	G 3/4	13.5	18	38	25
210 2040	G 1	17.5	22	46	25
210 2050	G 1 1/4	18	23.5	57	25
210 2060	G 1 1/2	19	25	64	25
210 2070	G 2	19	25.5	77	10
210 2080	G 2 1/2	20	26.5	92	10
210 2090	G 3	25.5	32.5	105	10



Tappo maschio  
Male plug  
Tapón macho

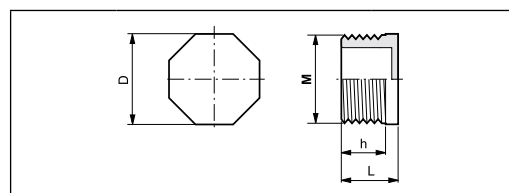



COD. CODE CÓD.	M (BSP)	h (mm)	L (mm)	D (mm)	
215 001	G 1/4	9	15	17	25
215 010	G 3/8	10.5	22	24	25
215 020	G 1/2	15.5	23	24	25
215 2030	G 3/4	22	34	27	25
215 040	G 1	19	30	36	25
215 050	G 1 1/4	21	27	43	25

**NYLON® PA66**

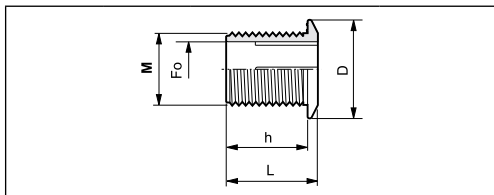

Bocchettone scarico  
Drain outlet  
Racor de desagüe



COD. CODE CÓD.	M (BSP)	h (mm)	L (mm)	D (mm)	F0 (mm)	
220 020	G 1/2	43	48	38	14	25
220 030	G 3/4	43	50	45	18	25
220 040	G 1	50	55	50	25	25
220 050	G 1 1/4	40	45	58	32	25
220 052	G 1 1/4	55	60	59	32	25
220 060	G 1 1/2	46	51.5	65.5	38	25
220 070	G 2	66.5	73.5	76	47.5	10
220 080	G 2 1/2	70	76	100	63.5	10



Manicotto per agitatore  
Mixer coupling  
Manguito para agitador

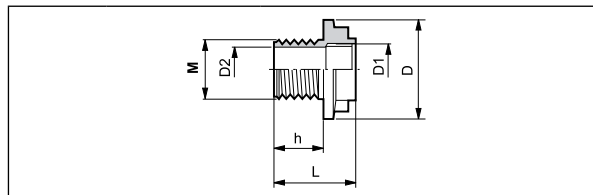

COD. CODE CÓD.	M (BSP)	h (mm)	L (mm)	D (mm)	D1	D2 (mm)	
225 224	M24 x 2	20	33	40	G 1/2 BSP	18	25



Raccordo livello atomizzatore (2 pezzi)  
Atomiser level fitting (2 pieces)  
Racor nivel atomizador (2 piezas)

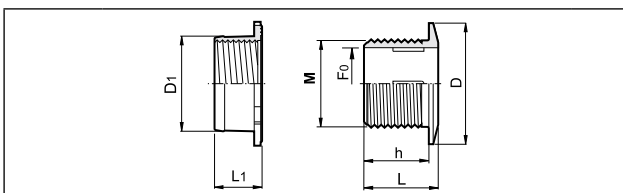

COD. CODE CÓD.	M	h (mm)	L (mm)	D (mm)	F0 (mm)	L1 (mm)	D1 (mm)	
260 010	G 2 (BSP)	45	52	84	50	33	66	25
260 020	M 78 x 2.5	52	62	108	67	50	91	25



**Nipplo simmetrico e passaparete**  
Symmetrical and bulkhead nipple  
Unión simétrico y pasapared

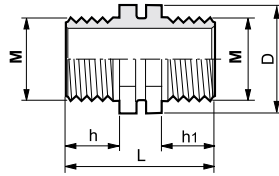

COD. CODE CÓD.	M (BSP)	h (mm)	h1 (mm)	L (mm)	D (mm)	
250 2020	G 1/2	18	18	48	32	25
250 2030	G 3/4	22	22	56	40	25
250 2040	G 1	22	22	56	45	25
250 2050	G 1 1/4	24	24	62	56	25
250 2060	G 1 1/2	24	24	62	62	10
250 2070	G 2	27	27	68	76	10
250 2080	G 2 1/2	32	32	78	92	10
250 2090	G 3	35	35	84	106	5
Passaparete	Bulkhead	Pasapared				
250 2021	G 1/2	38	18	68	32	25
250 2031	G 3/4	40	22	74	40	25
250 2041	G 1	45	22	79	45	25
250 2051	G 1 1/4	54	24	88	56	25
250 2061	G 1 1/2	50	24	88	62	10
250 2071	G 2	50	27	91	76	10
250 2081	G 2 1/2	65	32	111	92	10
250 2091	G 3	73	35	122	106	5



**Riduzione Maschio / Maschio**  
Male / Male reducer nipple  
Reduccion Macho / Macho

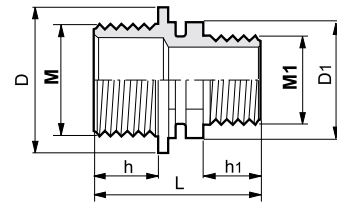

COD. CODE CÓD.	M (BSP)	M1 (BSP)	h (mm)	h1 (mm)	L (mm)	D (mm)	D1 (mm)	
240 2020	G 1/2	G 1/4	18	13	43	32	21	25
240 2021	G 1/2	G 3/8	18	16	46	32	27	25
240 2031	G 3/4	G 3/8	22	16	50	40	27	25
240 2032	G 3/4	G 1/2	22	18	52	40	32	25
240 2042	G 1	G 1/2	22	18	52	45	32	25
240 2043	G 1	G 3/4	22	22	56	45	40	25
240 2053	G 1 1/4	G 3/4	24	22	60	56	40	25
240 2054	G 1 1/4	G 1	24	22	60	56	45	25
240 2064	G 1 1/2	G 1	24	22	60	62	45	10
240 2065	G 1 1/2	G 1 1/4	24	24	62	62	56	10
240 2075	G 2	G 1 1/4	27	24	65	76	56	10
240 2076	G 2	G 1 1/2	27	24	65	76	62	10
240 2087	G 2 1/2	G 2	32	27	73	93	76	10
240 2097	G 3	G 2	35	27	76	106	76	10
240 2098	G 3	G 2 1/2	35	32	81	106	93	10



**Manicotto**  
Threaded coupling  
Manguito

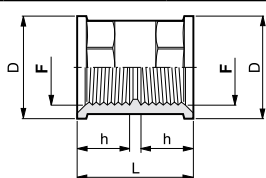

COD. CODE CÓD.	F (BSP)	h (mm)	L (mm)	D (mm)	
230 2010	G 3/8	17	38	27	25
230 2020	G 1/2	19	43	32	25
230 2030	G 3/4	23	51	40	25
230 2040	G 1	23	51	45	25
230 2050	G 1 1/4	25	55	56	25
230 2060	G 1 1/2	25	55	62	10
230 2070	G 2	28	61	76	10



**Giunto semplice**  
Threaded barrel nipple  
Unión simple

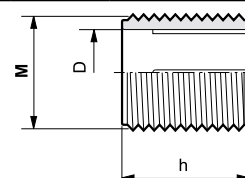

COD. CODE CÓD.	M (BSP)	h (mm)	D (mm)	
230 530	G 3/4	47	18	25
230 540	G 1	51	25	25
230 550	G 1 1/4	33.5	32	25
230 551	G 1 1/4	47.5	32	25
230 560	G 1 1/2	46	38	10
230 570	G 2	69	47	10



Riduzione Femmina / Femmina  
Female / Female reducer nipple  
Reduccion Hembra / Hembra

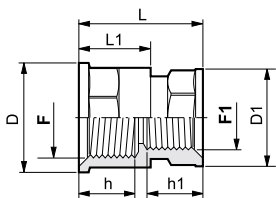

COD. CODE CÓD.	F (BSP)	F1 (BSP)	h (mm)	h1 (mm)	L (mm)	L1 (mm)	D (mm)	D1 (mm)	
235 2010	G 3/8	G 1/4	18	14	35	23	27	21	25
235 2020	G 1/2	G 1/4	19	14	37.5	25.5	32	21	25
235 2021	G 1/2	G 3/8	19	17	40.5	25.5	32	27	25
235 2031	G 3/4	G 3/8	23	17	44.5	29.5	40	27	25
235 2032	G 3/4	G 1/2	23	19	47	29.5	40	32	25
235 2042	G 1	G 1/2	23	19	47	29.5	45	32	25
235 2043	G 1	G 3/4	23	23	51	29.5	45	40	25
235 2053	G 1 1/4	G 3/4	25	23	53	32	56	40	25
235 2054	G 1 1/4	G 1	25	23	53	32	56	45	25
235 2064	G 1 1/2	G 1	25	23	53	32	62	45	10
235 2065	G 1 1/2	G 1 1/4	25	25	55	32	62	56	10
235 2075	G 2	G 1 1/4	28	25	58	35	76	56	10
235 2076	G 2	G 1 1/2	28	25	58	35	76	62	10



Riduzione Maschio / Femmina  
Male / Female reducer nipple  
Reduccion Macho / Hembra

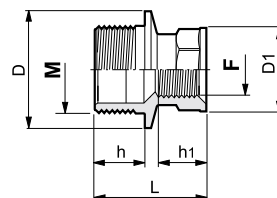

COD. CODE CÓD.	M (BSP)	F (BSP)	h (mm)	h1 (mm)	L (mm)	D (mm)	D1 (mm)	
245 010	G 3/8	G 1/4	13	10	23	22	22	25
245 2032	G 3/4	G 1/2	22	19	47.5	40	32	25
245 2042	G 1	G 1/2	22	19	47.5	45	32	25
245 2043	G 1	G 3/4	22	23	51.5	45	40	25
245 2053	G 1 1/4	G 3/4	24	23	53.5	56	40	25
245 2054	G 1 1/4	G 1	24	23	53.5	56	45	25
245 2064	G 1 1/2	G 1	24	23	53.5	62	45	10
245 2065	G 1 1/2	G 1 1/4	24	25	56	62	56	10
245 2075	G 2	G 1 1/4	27	25	59	76	56	10
245 2076	G 2	G 1 1/2	27	25	59	76	62	10
245 2097	G 3	G 2	35	28	72.5	106	76	10



Manicotto Maschio / Femmina  
Male / Female threaded coupling  
Manguito Macho / Hembra

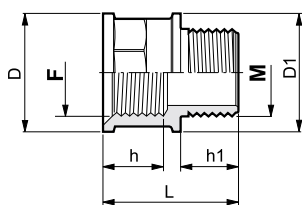

COD. CODE CÓD.	M (BSP)	F (BSP)	h (mm)	h1 (mm)	L (mm)	D (mm)	D1 (mm)	
245 2022	G 1/2	G 1/2	19	18	43.5	32	32	25
245 2033	G 3/4	G 3/4	23	22	51.5	40	40	25
245 2044	G 1	G 1	23	22	51.5	45	45	25
245 2055	G 1 1/4	G 1 1/4	25	24	56	56	56	25
245 2066	G 1 1/2	G 1 1/2	25	24	56	62	62	10
245 2077	G 2	G 2	28	27	62	76	76	10



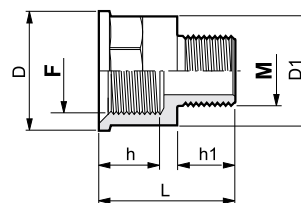

Riduzione Femmina / Maschio  
Female / Male reducer nipple  
Reduccion Hembra / Macho

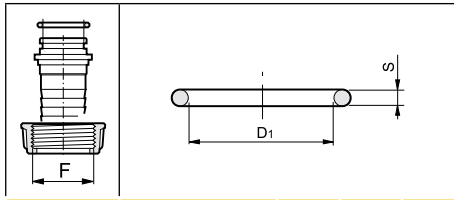

COD. CODE CÓD.	F (BSP)	M (BSP)	h (mm)	h1 (mm)	L (mm)	D (mm)	D1 (mm)	
245 2001	G 3/8	G 1/4	17	11	36	27	22	25
245 2002	G 1/2	G 1/4	19	13	38.5	32	21	25
245 2012	G 1/2	G 3/8	19	16	41.5	32	27	25
245 2013	G 3/4	G 3/8	23	16	45.5	40	27	25
245 2023	G 3/4	G 1/2	23	18	47.5	40	32	25
245 2024	G 1	G 1/2	23	18	47.5	45	32	25
245 2034	G 1	G 3/4	23	22	51.5	45	40	25
245 2035	G 1 1/4	G 3/4	25	22	54	56	40	25
245 2045	G 1 1/4	G 1	25	22	54	56	45	25
245 2046	G 1 1/2	G 1	25	22	54	62	45	10
245 2056	G 1 1/2	G 1 1/4	25	24	56	62	56	10
245 2057	G 2	G 1 1/4	28	24	59	76	56	10
245 2067	G 2	G 1 1/2	28	24	59	76	62	10
245 2079	G 3	G 2	27	25	60	106	106	10

**Guarnizioni per raccordi portagomma con OR**  
Gaskets for hose fittings with OR  
Juntas para racores portamangueras con OR



F (BSP)	COD. CODE CÓD.	D1 (mm)	S (mm)	
G 3/8	G 11057	9.1	2.6	50
G 1/2	G 11060	10.5	2	50
G 3/4	G 10031	13.1	2.6	50
G 1	G 10041	20.2	2.6	50
G 1 1/4	G 10051	26.7	2.6	50
G 1 1/2	G 10061	29.2	3	50
G 2	G 10071	39.3	2.6	50
G 2 1/2	G 10081	56.7	3.5	25
G 3	G 10091	68.3	3.5	10

**Guarnizioni per raccordi portagomma con sede piana**  
Gaskets for hose fittings with flat seat  
Juntas para racores portamangueras con asiento plano

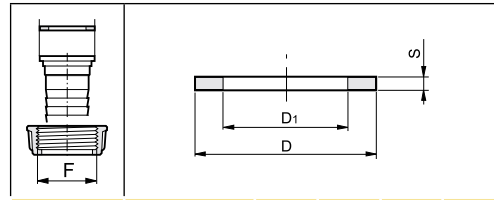

F (BSP)	COD. CODE CÓD.	D (mm)	D1 (mm)	S (mm)	
G 3/8	G 424 190	14	10	2	25
G 1/2	G 40012	19.2	11.5	2.5	50
G 3/4	G 40013	24.5	17	2.5	50
G 1	G 40014	30.7	20	2.5	50
G 1 1/4	G 40015	39.5	27.5	2.5	50

**Guarnizioni per raccordi a tenuta con OR**  
Gaskets for OR seal fittings  
Juntas para racores con estanqueidad con OR

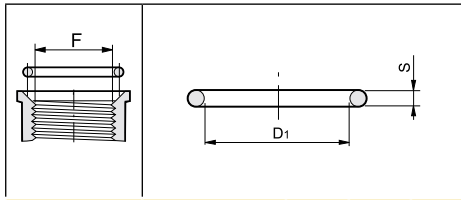

F (BSP)	COD. CODE CÓD.	D1 (mm)	S (mm)	
G 1/2	G 10041	20.2	2.6	50
G 3/4	G 11058	25	2.6	50
G 1	G 11059	29.8	2.6	50
G 1 1/4	G 10052	39.7	3.5	50
G 1 1/2	G 10062	47.2	3.5	50
G 2	G 10073	58.7	3.5	25
G 2 1/2	G 10082	74.6	3.5	25
G 3	G 10092	85.5	3.5	10

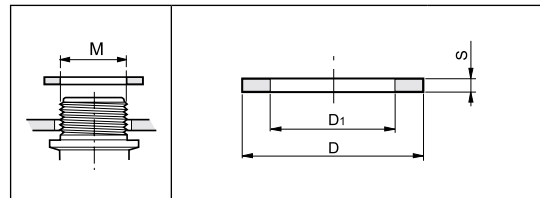

**Guarnizioni per filetti maschio passaparete**  
Gaskets for bulkhead male threads  
Juntas para roscas macho pasapared

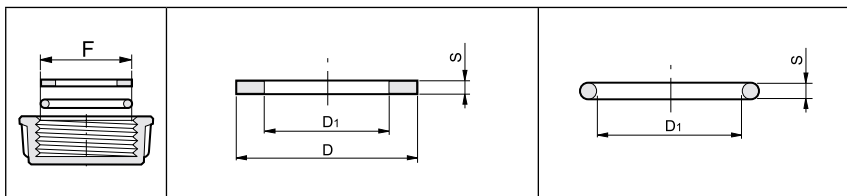

M	COD. CODE CÓD.	D (mm)	D1 (mm)	S (mm)	
G 1/2 (BSP)	G 40002	33	21	2	50
G 3/4 (BSP)	G 40015	39.5	27.5	2.5	50
G 1 (BSP)	G 40004	45	33	3	50
G 1 1/4 (BSP)	G 40005	60	40	4	50
G 1 1/2 (BSP)	G 40006	67	47	3	50
G 2 (BSP)	G 40007	86	59	4	25
G 2 1/2 (BSP)	G 40008	94.5	76	4	25
G 3 (BSP)	G 40009	110	90	4	25
M24 x 2 (mm)	G 40015	39.5	27.5	2.5	50

**Guarnizioni per tappi femmina**  
Gaskets for blanking caps  
Juntas para taponos hembra



F	COD. CODE CÓD.	D (mm)	D1 (mm)	S (mm)		COD. CODE CÓD.	D1 (mm)	S (mm)	
G 3/8 (BSP)	---	---	---	---	---	G 11068	12	2.6	50
G 1/2 (BSP)	---	---	---	---	---	G 10020	14	3	50
G 3/4 (BSP)	G 40013	24.5	17	2.5	50	---	---	---	---
G 1 (BSP)	G 40014	30.7	20	2.5	50	---	---	---	---
G 1 1/4 (BSP)	G 40015	39.5	27.5	2.5	50	---	---	---	---
G 1 1/2 (BSP)	G 40004	45	33	3	50	---	---	---	---
G 2 (BSP)	G 40005	60	40	4	50	---	---	---	---
G 2 1/2 (BSP)	G 40010	75	55	4	25	---	---	---	---
G 3 (BSP)	G 40007	86	59	4	25	---	---	---	---



- Compatibili con gli accoppiatori MIL-C-27487
- Leve di bloccaggio in acciaio INOX per una massima resistenza meccanica ed alla corrosione (2 leve nei modelli fino a 3" e 3 leve nei modelli da 4")
- Il materiale impiegato, polipropilene rinforzato con fibra di vetro, assicura un'ottima resistenza meccanica e agli agenti chimici
- Su richiesta disponibili anche in Nylon rinforzato con fibra di vetro
- Filettatura GAS (NPT a richiesta)
- Nelle versioni con filettatura GAS femmina è presente la sede conica per la tenuta con O-ring (compatibile con tutta la nuova produzione di raccorderia ARAG)
- Pressione di utilizzo max 9 BAR (130 PSI) per i modelli da i 3/4" a 2"; max 5 BAR (75 PSI) per i modelli da 3" e 4"
- Guarnizioni di tenuta standard in EPDM (Viton® e NBR a richiesta)

- Suitable to couplings MIL-C-27487
- STAINLESS STEEL locking levers for maximum mechanical strength and corrosion resistance (2 locking levers up to 3" models and 3 levers for 4" models)
- The material used, fibreglass-reinforced polypropylene, ensures excellent mechanical strength and good resistance against chemical agents
- On request, also available in fibreglass-reinforced Nylon
- BSP threads (NPT on request)
- A tapered seat for the O-ring seal is fitted in the female thread BSP versions (compatible with all new ARAG fittings)
- Max. working pressure 9 BAR (130 PSI) for the 3/4" to 2" models; max. 5 BAR (75 PSI) for the 3" and 4" models
- EPDM standard gaskets (Viton® and NBR on request)

- Compatibles con los acoples MIL-C-27487
- Levas de bloqueo de acero INOX, máxima resistencia mecánica y a la corrosión (2 levas hasta modelos de 3" y 3 levas para el modelo de 4")
- El material utilizado, polipropileno reforzado con fibra de vidrio, asegura una óptima resistencia mecánica y a los agentes químicos
- A pedido están disponibles en Nylon reforzado con fibra de vidrio
- Roscas disponibles GAS (NPT a pedido)
- Las versiones con rosca GAS hembra incorporan el asiento conico para la estanqueidad con O-ring (compatible con toda la nueva producción de racores ARAG)
- Presión de utilización Máx 9 BAR (130 PSI) para los modelos de 3/4" a 2", máx. 5 BAR (75 PSI) para los modelos de 3" y de 4".
- Juntas de estanqueidad en EPDM (Viton® y NBR a pedido)

### A Adattatore maschio / Filetto femmina Male adapter / Female thread Adaptador macho / Rosca hembra



COD. CODE CÓD.	Corpo Size Cuerpo	F (BSP)
181 03A2	3/4"	G 1/2
181 03A	3/4"	G 3/4
181 04A	1"	G 1
181 05A	1 1/4"	G 1 1/4
181 06A5	1 1/2"	G 1 1/4
181 06A	1 1/2"	G 1 1/2
181 07A	2"	G 2
181 09A8	3"	G 2 1/2
181 09A	3"	G 3
181 0AA	4"	G 4

### B Accoppiatore femmina / Filetto maschio Female coupler / Male thread Acople hembra / Rosca macho



COD. CODE CÓD.	Corpo Size Cuerpo	M (BSP)
181 03B2	3/4"	G 1/2
181 03B	3/4"	G 3/4
181 04B	1"	G 1
181 05B	1 1/4"	G 1 1/4
181 06B5	1 1/2"	G 1 1/4
181 06B	1 1/2"	G 1 1/2
181 07B	2"	G 2
181 09B8	3"	G 2 1/2
181 09B	3"	G 3
181 0AB	4"	G 4



### C Accoppiatore femmina / Portagomma Female coupler / Hose fitting Acople hembra / Portamangueras

COD. CODE CÓD.	Corpo Size Cuerpo	Ø (BSP)
181 03C2	3/4"	13
181 03C	3/4"	19
181 04C	1"	25
181 04C5	1"	32
181 05C30	1 1/4"	30
181 05C	1 1/4"	32
181 06C5	1 1/2"	32
181 06C	1 1/2"	38
181 06C40	1 1/2"	40
181 07C	2"	50
181 07C53	2"	53
181 07C55	2"	55
181 09C60	3"	60
181 09C8	3"	63
181 09C	3"	75
181 09C78	3"	78
181 09C87	3"	87
181 0AC105	4"	105

Possano essere accoppiati gli articoli aventi lo stesso colore.  
The items with same color can be coupled together.  
Es posible conectar los articulos que tienen el mismo color.



# ACCOPIATORI CON BLOCCAGGIO A CAMME COUPLINGS WITH CAM LOCKING ACOPLES CON BLOQUEO DE EXCENTRICAS



FITTINGS



## D Accoppiatore femmina / Filetto femmina Female coupler / Female thread Acople hembra / Rosca hembra

COD. CODE CÓD.	Corpo Size Cuerpo	F (BSP)
181 03D2	3/4"	G 1/2
181 03D	3/4"	G 3/4
181 04D	1"	G 1
181 05D	1 1/4"	G 1 1/4
181 06D5	1 1/2"	G 1 1/4
181 06D	1 1/2"	G 1 1/2
181 07D	2"	G 2
181 09D8	3"	G 2 1/2
181 09D	3"	G 3
181 0AD	4"	G 4



## E Adattatore maschio / Portagomma Male adapter / Hose fitting Adaptador macho / Portamangueras

COD. CODE CÓD.	Corpo Size Cuerpo	Ø (BSP)
181 03E2	3/4"	13
181 03E	3/4"	19
181 04E	1"	25
181 04E5	1"	32
181 05E30	1 1/4"	30
181 05E	1 1/4"	32
181 06E5	1 1/2"	32
181 06E	1 1/2"	38
181 06E40	1 1/2"	40
181 07E	2"	50
181 07E53	2"	53
181 07E55	2"	55
181 09E60	3"	60
181 09E8	3"	63
181 09E	3"	75
181 09E78	3"	78
181 09E87	3"	87
181 0AE105	4"	105



## F Adattatore maschio / Filetto maschio Male adapter / Male thread Adaptador macho / Rosca macho

COD. CODE CÓD.	Corpo Size Cuerpo	M (BSP)
181 03F2	3/4"	G 1/2
181 03F	3/4"	G 3/4
181 04F	1"	G 1
181 05F	1 1/4"	G 1 1/4
181 06F5	1 1/2"	G 1 1/4
181 06F	1 1/2"	G 1 1/2
181 07F	2"	G 2
181 09F8	3"	G 2 1/2
181 09F	3"	G 3
181 0AF	4"	G 4



## G Tappo per accoppiatore femmina Plug for female coupler Tapón para acople hembra

COD. CODE CÓD.	Corpo Size Cuerpo
181 03G	3/4"
181 04G	1"
181 05G	1 1/4"
181 06G	1 1/2"
181 07G	2"
181 09G	3"
181 0AG	4"



## H Tappo per adattatore maschio Plug for male adapter Tapón para adaptador macho

COD. CODE CÓD.	Corpo Size Cuerpo
181 03H	3/4"
181 04H	1"
181 05H	1 1/4"
181 06H	1 1/2"
181 07H	2"
181 09H	3"
181 0AH	4"



## Molla anti apertura per Cam Lock Locking spring for Cam-Lock couplers Traba anti-apertura para acople rapido

COD. CODE CÓD.	Corpo Size Cuerpo
181 030	3/4"
181 040	1"
181 050	1 1/4"
181 060	1 1/2"
181 070	2"
181 090	3"

- Elimina aperture accidentali delle leve dovute a vibrazioni eccessive o urti
- It prevents accidental opening of the levers in case of strong vibrations or bumps
- Elimina el desenganche accidental de las levas, debido a bibraciones exesivas o golpes

Possono essere accoppiati gli articoli aventi lo stesso colore.  
The items with same color can be coupled together.  
Es posible conectar los articulos que tienen el mismo color.